

● Vee Mountings



Features

Vee mountings have ideal stiffness characteristics for rail vehicle engine suspensions. The vertical stiffness rate ensures that when the mounting is properly loaded, the vertical natural frequency doesn't coincide with the body bending frequency. The high longitudinal stiffness controls shunting shock motion. The mounting is usually connected to the sole bars via the base casting, and a buffer is attached to the Vee section casting to limit tensile loads.

The Vee mounting has the following features:

- Three dissimilar translational stiffnesses for the best vibration isolation and motion control.
- Strong castings for safety and reliability.

Metalastik® type Vee Mountings

A high load capacity mounting with relatively large rubber volume providing a high degree of vibration and noise isolation and makes it ideally suited for suspending engines installed in public service and goods vehicles.

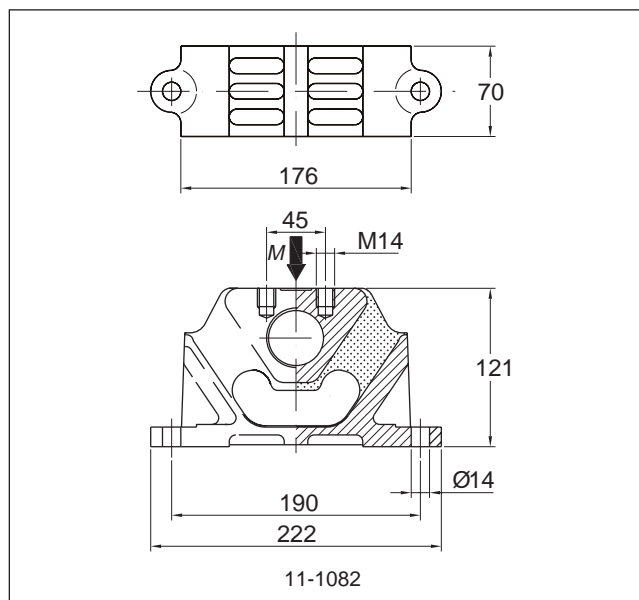
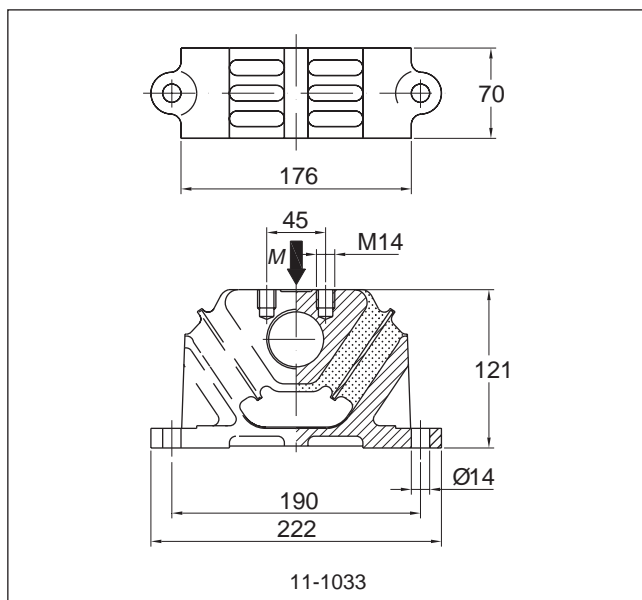

Type	Art.No.	M-Max (kg)	Weight (kg)
Vee mountings	11-1082-55 (55° IRH)	210	4.2
	11-1082-65 (65° IRH)	315	4.2
	11-1033-50 (50° IRH)	470	4.5
	11-1033-60 (60° IRH)	710	4.5