



**Features**

Type HA is a height adjuster made in corrosion protected grade 8 steel. The steel is zinc plated and chromated according to DIN 50691/ISO 2081. The height adjuster is supplied complete with washer and nut for fastening to the mounting and two nuts and a lock washer for the engine foot fastening. The HA height adjustment facilitates precise coupling alignment for engine installations and boat building tolerances.

**Trelleborg Industrial AVS - Height Adjusters**

Type HA is available in various sizes to suit the small and medium range of Trelleborg Industrial AVS mountings, as listed in the table below. It allows mountings to be retrofitted to existing installations where original spares are unobtainable.

**Note:**

- ▼ For optimum solutions where close coupling tolerances are required, allow the mountings to settle for 48 hours before final alignment of the engine installation.
- ▼ For securing the bolt into the mounting, it is recommended to apply thread lock adhesive.
- ▼ The height adjuster HA can be used together with Novibra type M-mount. See description of M-mount.

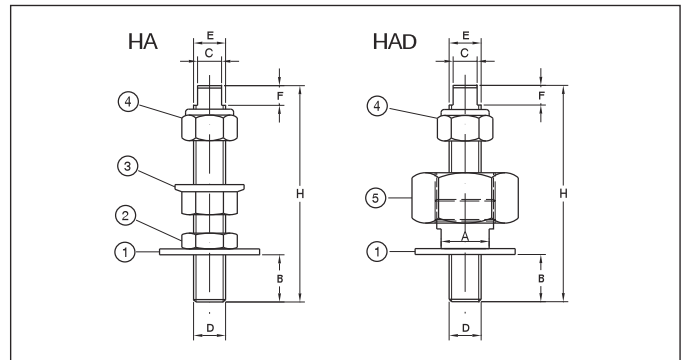
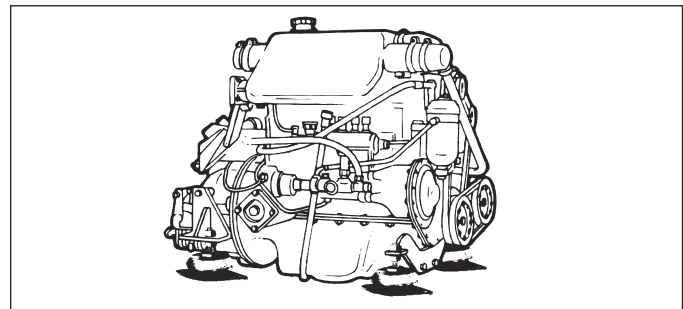

**Height Adjusters can be used together with:**

HA 12/12	RAB, RA 100 M 12, RA 200 M 12, RAEM 60,
HA 12/16	RAEM 125 M 12, RAEM 350 M 12, 17-1463,
HAD12/16	Cushyfloat 17-1600, SIM 100
HA 16/16	RA 350 M 16, RA 500, RA 800,
HAD16/16	RAEM M 16, RAEM 800,
HA 16/20	Cushyfloat 17-1609, SIM 200,
HAD16/20	Cushyfoot 17-0213, 17-0290, 17-0346
HA 20/20	Cushyfloat 17-1657, SIM 300
HAD20/20	
HAD24/24	Cushyfloat 17-1841

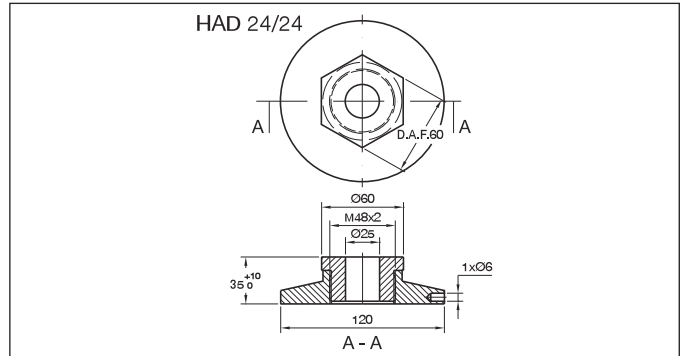

Type	Part no.	Dimensions in mm						1 Washer	2 Hexagon low nut	3 Hexagon flange nut	4 Lock nut plastic insert	5 Fine thread adjusting unit	
		H	D	E	A	B	C						F
HA 12/12	40-04704	95	M12	M12		20	D.A.F.8	8	37*12*3	M12	M12	M12	
HA 12/16	40-06068	105	M12	M16		20	D.A.F.12	10	44*15*3	M16	M16	M16	
HA 16/16	40-04705	110	M16	M16		24	D.A.F.12	10	50*15*3	M16	M16	M16	
HA 16/20	20-00511	130	M16	M20		24	D.A.F.12	10	56*20*4	M20	M20	M20	
HA 20/20	40-02515	135	M20	M20		30	D.A.F.12	10	60*21*4	M20	M20	M20	
HAD 12/16	20-00513	105	M12	M16	D.A.F.24	20	D.A.F.12	10	44*15*3			M16	M30*1,5
HAD 16/16	20-00514	110	M16	M16	D.A.F.24	24	D.A.F.12	10	50*15*3			M16	M30*1,5
HAD 16/20	20-00515	130	M16	M20	D.A.F.27	24	D.A.F.12	10	56*20*4			M20	M36*2
HAD 20/20	20-00516	135	M20	M20	D.A.F.27	30	D.A.F.12	10	60*21*4			M20	M36*2
HAD 24/24	20-00517	see drawing											