



### Features

A heavy duty flexible bearing which combines high load capacity with the ability to accommodate torsional and angular movements in all planes without lubrication and metal to metal wear. It is available with centre bore or solid member depending on fixing requirements.

### Metalastik® type Spherilastik™ Bearings

Typical uses include traction and braking reaction rods for rail, road and off-road vehicles, hydraulic damper fixings and other applications where a high duty bearing of compact size is required.

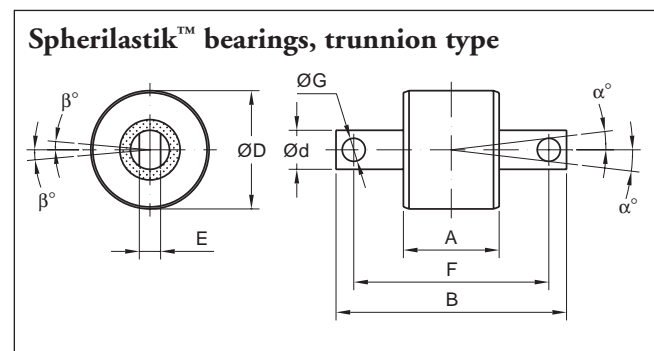
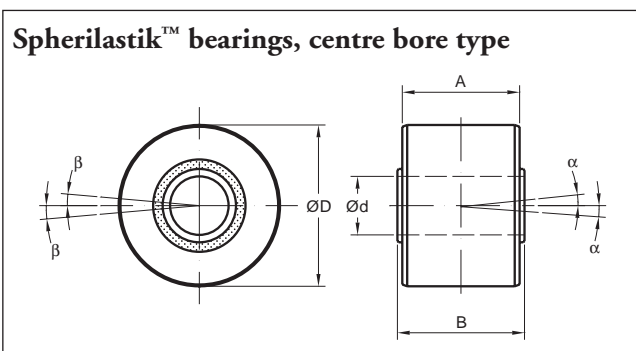

Type	Art.No	d	Dimensions in mm					Radial		Torsion		Bending		Weight (kg)	
			D	A	B	E	F	G	Stiffness kN/mm	Max load kN	Stiffness kNm/rad	±β degrees	Stiffness kNm/rad		±α degrees
Spherilastik™ bearings	13-1316-60 (60° IHR)	25.4	66.7	47.6	54			70	34	0.9	8	0.9	6	0.84	
	13-1006-60 (60° IHR)	28.6	90.5	70	76.2			93	58	2.8	8	2.8	6	2.5	
Centre bore type	13-2106-60 (60° IHR)	28.6	90.5	70	76.2			100	58	2.8	8	2.8	6	1.8	
	13-1285-60 (60° IHR)	38.1	104.8	76.2	82.6			90	78	4.5	8	3.8	7	3.4	
Trunnion type	13-2202-65 (65° IHR)	35	66.7	47.6	120	20	90	13	70	34	0.7	8	0.9	6	1.2
	13-2033-60 (60° IHR)	40	84	65	155	20	120	16.5	150	75	2.8	6	2.8	6	2.8