



Features

UH is an anti-vibration mounting designed to accommodate axial static and shock loads in both directions. The dynamic natural frequency is constant irrespective of the static load.

When fitted with overload/rebound washers, a high strength fail-safe installation is provided.

Moreover, it is possible to alter the characteristics of the mounting by providing a dome-shaped washer at the upper rubber section. This will provide impact resistance to deflection beyond the permissible limit.

Installation reduces build tolerances.

UH is available in 2 standard versions allowing different maximum loads i.e. type UH 50 to a load of 250 kg and type UH 70 to 400 kg per mounting.

Note: Maximum tightening torque of bolts:

- ▼ UH 50 80 Nm
- ▼ UH 70 120 Nm

Novibra® type UH™

Mounting type UH™ is particularly suitable for the suspension of both mobile and static cabs as well as platforms on agricultural vehicles.

Effectively isolating vibration and noise, the UH™ mounting also protects tanks and ancillary equipment against metal fatigue caused by chassis distortion.

Specific applications can be found on:

- ▼ Tractors
- ▼ Excavators
- ▼ Compactors
- ▼ Lifting cranes
- ▼ Forklift trucks
- ▼ Forestry vehicles
- ▼ Street sweepers
- ▼ Combine harvester
- ▼ Off-road equipment
- ▼ Construction vehicles
- ▼ Wheel-mounted loaders

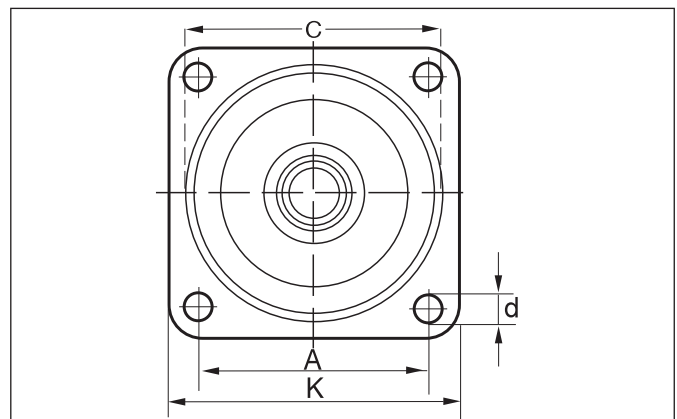
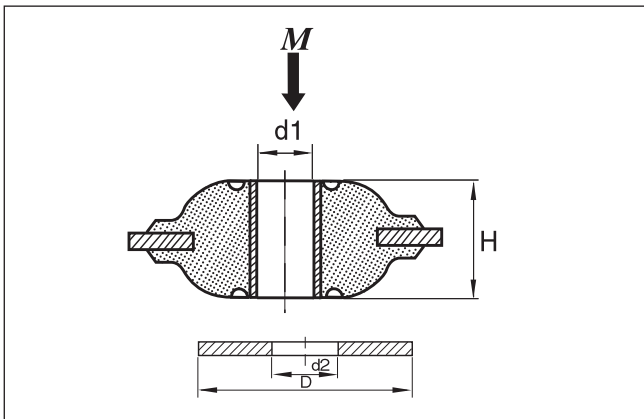

Type	Drawing no.	Part no.	Dimensions in mm						M-Max (Kg)	Weight (Kg)
			K	A	H	C	d	d1		
UH 50	15-4131	10-00086	100,5	80,4	37	91	10,5	15	250	0,41
UH 70	15-4132	10-00088	100,5	0,4	37	91	10,5	17	400	0,41
			d2	D	t					
UH Washer	N/A	20-00608	17	75	6					

Note: The natural frequencies and degrees of isolation are based on dynamic characteristics of the mountings.

Load per mounting (kg)

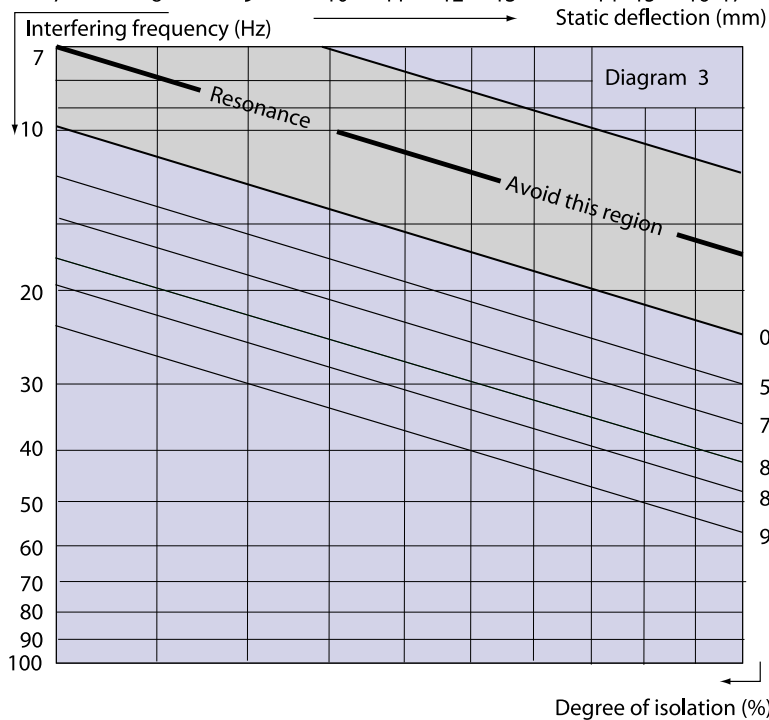
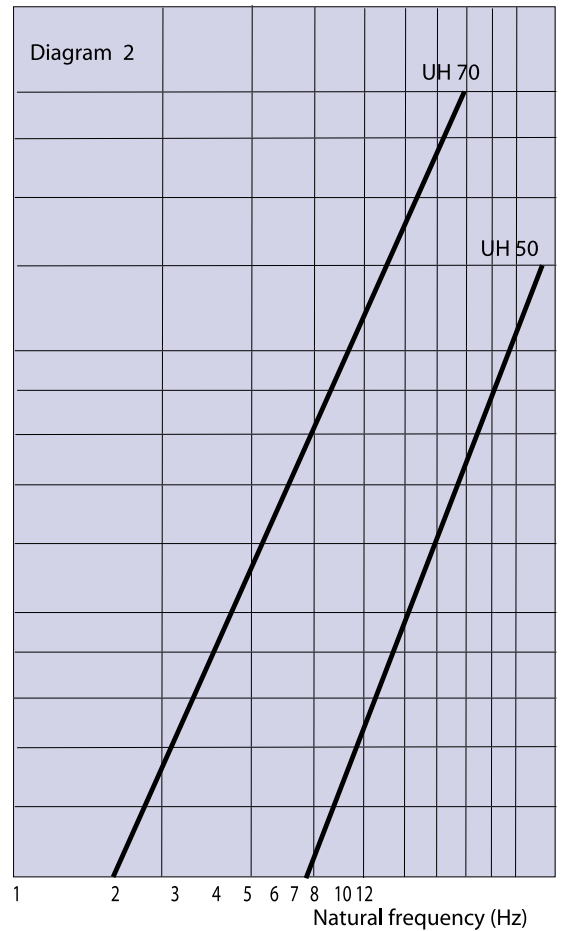
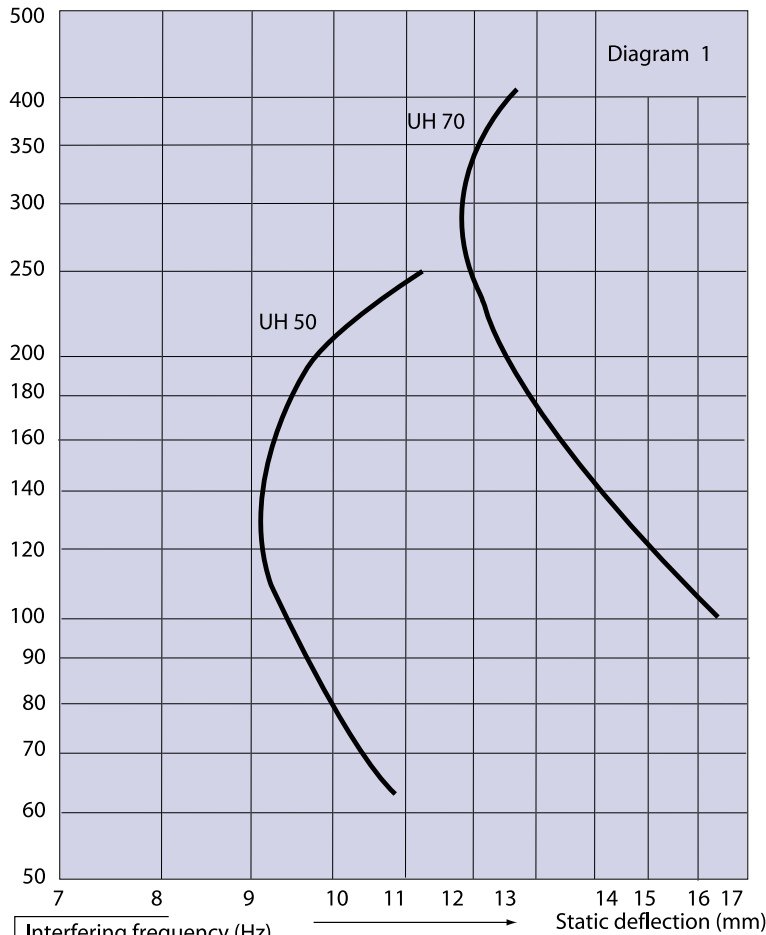

To select correct mounting, following data are needed:
 1) Load per mounting (kg)
 2) Interfering frequency (Hz) (Hz = rpm / 60)
 Select correct load line in diagram 1 and correct interference line in diagram 3. The load line intersects with required type of mounting.
 Connect this intersection point vertically down to the interference line in diagram 3. Here, on the sloping curve, the isolation degree is indicated.
 For static deflection, see diagram 2.

