

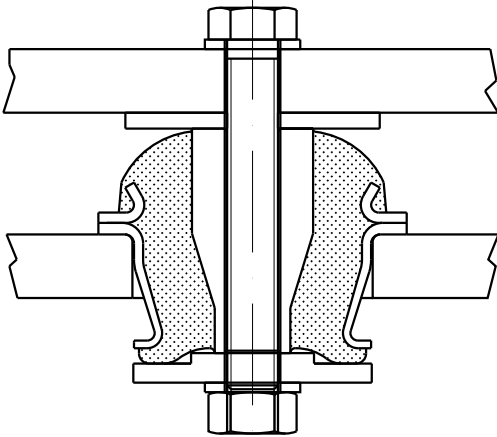

Installation Guidelines

Metacone™ and HK™

Always use appropriate washers when installing conical mountings! This recommendation refers also to mountings type Cab Mountings, UH™ and EH™.



M™ Mountings

The underside surface of the suspended unit which rests on type M mountings should have an area of at least the diameter shown in the diagram and table. Otherwise a thick washer of diameter E should be fitted.

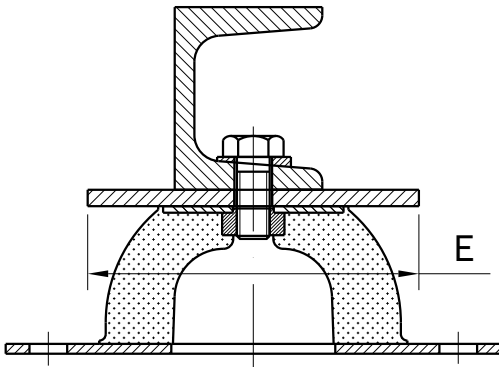

M mounting	E (mm)
M7	43
M25	56
M50	76
M100	96
M200	101
M400	125
M600	165
M1500	260

Loading directions

Do not install antivibration mountings in a way that causes the rubber to work in tension.

Compression and shear are the correct loading directions!

Take this into consideration for mounting types: Bobbins, M™, Two Bolt Instrumountings, Equi-Frequency, type SAW™, Rectangular SAW™ and Circular SAW™.

